

Cisco *live!*
February 20 - 24, 2017 • Berlin



Your Time Is Now

Designing High Density SP & DC Networks with NCS 5500

Iqbal Syed, Senior Product Marketing Manager

BRKSPG-1001



Session Abstract

The Network Convergence System 5500 (NCS 5500) Series offers industry-leading density of routed 100-GE ports for high-scale WAN aggregation. The NCS 5500 Series is designed to efficiently scale between data centers and large enterprise, web, and service provider WAN and aggregation networks.

The NCS 5500 is part of the Cisco's SP router portfolio family. The platform runs on IOS XR 64bit Linux which brings a lot of software innovation in areas such Containerization, 3rd party apps hosting & automation capabilities. NCS 5500 is being adopted by many customers around the world for many different variety of applications.

In this session, the audience will learn about how they can utilize the NCS 5500 series to effectively design and implement highly dense, scalable and Software Defined Networking (SDN) ready WAN, SP and DC Spine networks. The session will go over various design options with details on use cases and applications where NCS 5500 would be best suited.

Related Sessions

- **BRKSPG-2900** : Wednesday @ 9 AM, Nicolas Fevrier
Cloud Scale Networking: NCS 5500 and NCS 5000 Series Deep dive
- **BRKSPG-2509** : Wednesday @ 4:30 PM, Ahmad Bilal, Samir Thoria
BGP-EVPN and SR Fabric - Addressing the evolving Data Center requirements
- **BRKRST-1124** : Tuesday @ 11:15 AM, Leonir Hoxha
Introduction to Segment Routing
- **BRKRST-3122** : Thursday @ 2:30 PM, Clarence Filisfilis
Segment Routing: Technology deep-dive and advanced use cases
- **BRKSPG-2303** : Wednesday @ 11:30 AM, Santiago Alvarez
Model-driven programmability for Cisco IOS XR
- **BRKNMS-2303** : Tuesday @ 4:45 PM, Sushin S, Katrina Pickett
Efficiently Managing Optical Data Center Interconnects
- **BRKOPT-2000** : Thursday @ 11:30 AM, Randy Zhang
Deploying Data Center Interconnect with Wavelength Division Multiplexing

Agenda

- Cisco NCS 5500 Family Overview
- NCS 5500 Features & Scale
- IOS-XR Innovations
- SPDC Design Options and Examples
- Data Center Interconnect Design
- Conclusion & References

- ✓ *Cisco NCS 5500 Family Overview*
- *NCS 5500 Features & Scale*
- *IOS-XR Innovations*
- *SPDC Design Options and Examples*
- *Data Center Interconnect Design*
- *Conclusion & References*

Cisco NCS 5500 Family Overview

IOS XR Family

Innovations in Software Hardware and System Design



Virtual RR/PE/DC Forwarder

Cisco IOS-XRv 9000

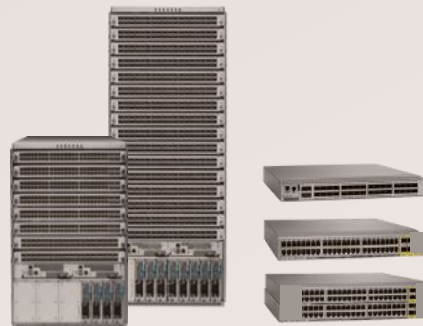

Cisco NCS 5500 & NCS 5000



Cisco ASR 9000, CRS & NCS 6000

OPTIMIZED Cisco vXR Software



Elastic



Cost Optimized



Ultra-high Density



Carrier Grade



Programmability and Automation

Cisco NCS 5000 Series

NCS 5001, Fixed 1RU



1.2Tbps @275W
40xSFP+ (1/10GE)
and 4xQSFP28 (100GE)

NCS 5002, Fixed 2RU



1.2Tbps@500W
80xSFP+ (1/10GE)
and 4xQSFP28 (100GE)

NCS 5011, Fixed 1RU



3.2Tbps @500W
32xQSFP28 (40GE /100GE)
Dense 100G Platform

- Latest 28nm Technologies
- CPU – Intel IVB Gladden, 4 Cores, 2.5GHz/Mem – 16GB
- Front to Back/Back to Front Airflow
- Redundant & Modular Fan Tray and AC/DC Power supply
- 16MB Buffers
- 128K FIB, 16K MPLS Labels

- Intel IvyBridge CPU 1.8GHz, 4 cores
- Front to Back/Back to Front Airflow
- Redundant Modular Fan Tray and hot-swappable AC/DC Power supply
- 16MB Buffers
- 128K FIB, 16K MPLS Labels

NCS 5500 Product Family

Innovations in Software, Hardware, and System Design

Shipping now

- **NCS 5508**

Modular 8 slots
13 RU (1/3 rack)
28.8 Tbps ~ 7000 W

- **NCS 5501**

Fixed 1 RU
800 Gbps @ 243 W

- **NCS 5504**

Modular 4 slots
7 RU
14.4 Tbps ~ 4000W*

- **NCS 5516**

Modular 16 slots
21 RU (1/2 rack)
57.6 Tbps @ ~15000 W

- **NCS 5502**

Fixed 2 RU
4.8 Tbps @ 1450 W

Q3
CY17



NCS 5501



NCS 5502



NCS 5504

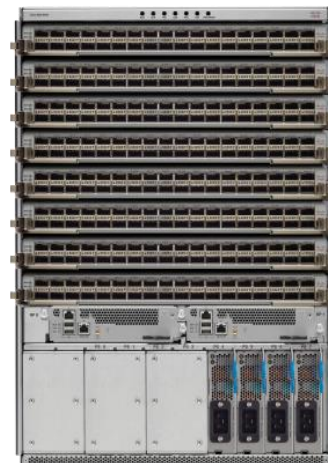

NCS 5508



NCS 5516



*Engineering estimates. All w/ SR optics at typical temps and packet rate

NCS 5500 Family Attributes

Common characteristics for all NCS 5500 platforms

- Highest density & lowest power
 - Integrated forwarding and fabric interface
 - 28nm ASIC process
 - 3rd generation modular QSFP28 100G optics
- 10/25/40/50/100GE interface support*
- Feature parity among NCS 5500 systems
- Deep Virtual Output Queue Buffers
 - Small (16 MB) on-chip buffers
 - 4GB off-chip GDDR5 memory for additional buffering



Flexible
Options



Highly Scalable



Low
Power
Usage

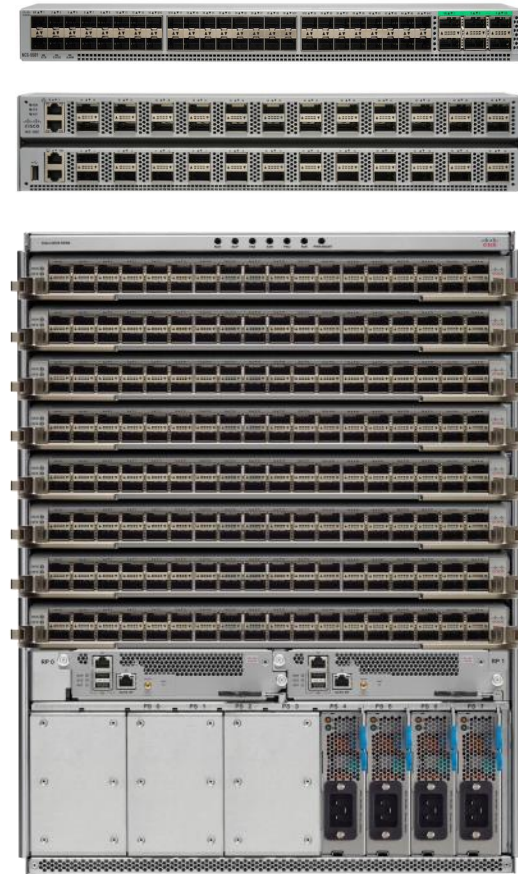

NCS 5508 Modular System

- 28.8 Tbps @ 6920 W = 0.24 W/Gbps
288 QSFP28 or QSFP+ ports
- 13 RU – 1/3 rack (86.4 Tbps/rack)
- 8 line card slots
100GE QSFP with 40G QSFP+ compatibility
LC options for FIB and ACL scale
- Redundant Hardware
8 power supplies AC/DC – N+1 & N+N redundancy
6 Fabric Cards and 3 Fan Trays
2 Route Processors, 2 System controllers
NEBS via air filter door and enclosure

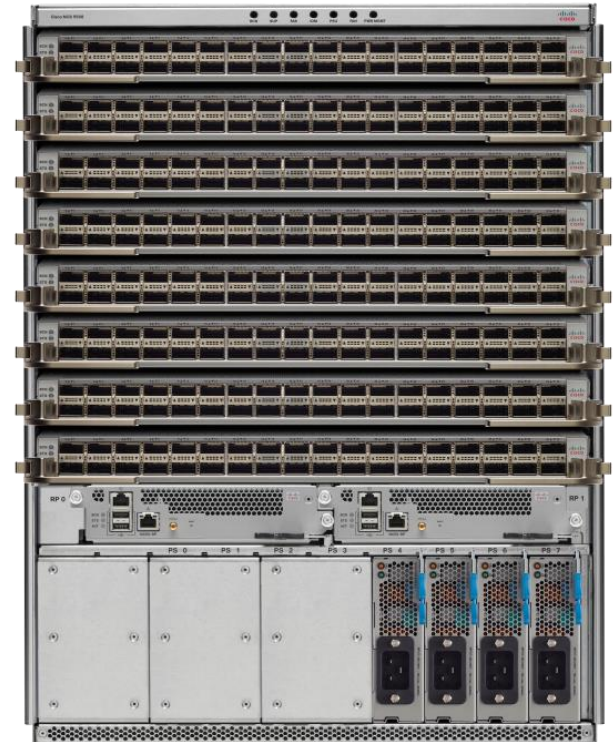

NCS 5500 Modular System Comparison

Orthogonal chassis design for cleaner & true front to back airflow

High Voltage AC/DC PSU for better efficiency

Intelligent System Fans

80 Plus Platinum Power supplies

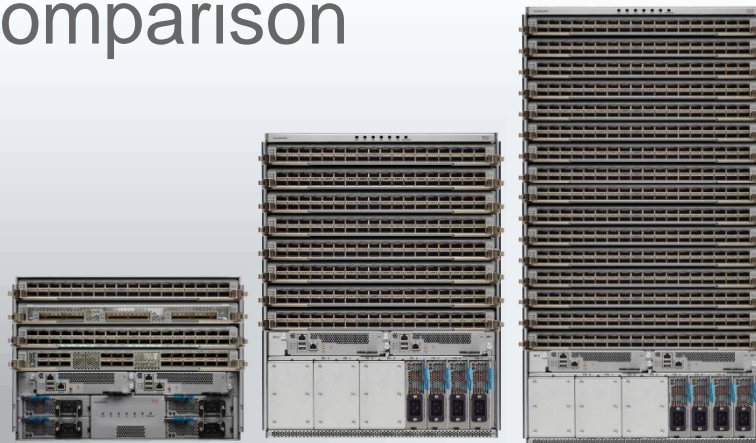

	NCS 5504	NCS 5508	NCS 5516
LC Slots / # of 100G	4 / 144	8 / 288	16 / 576
Rack Unit (RU)	7	13	21
Power Usage (Typ)	~4KW	~ 7KW	~ 15KW
Watts / Gbps	0.27	0.24	0.26
PSU Options	4 x AC/DC	8 x AC/DC	10 x AC/DC
PSU Redundancy	N+1 or N+N	N+1 or N+N	N+1 or N+M

True Front-To-Back Airflow

Streamlined Operations For Next-Generation Network Designs

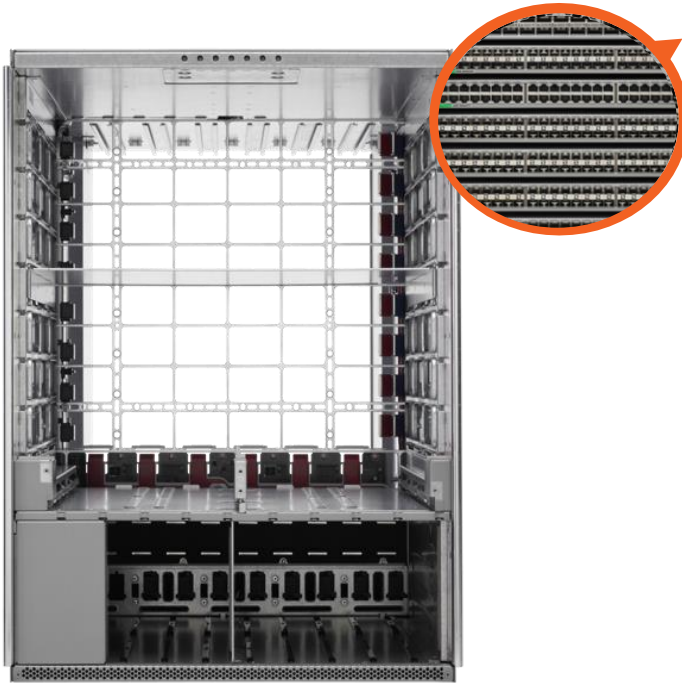

No Mid Plane and Perforated Faceplate for True Front-to-Back Cooling

- Save Cooling and Power
- Same chassis for multiple generations of line cards and fabric modules

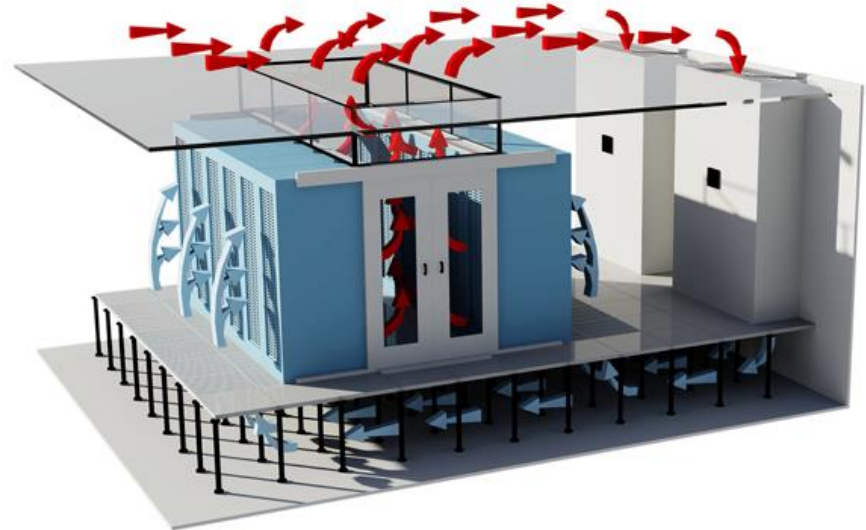

Modular Line Cards



Shipping
Now

36 Port 100GE Internal TCAM (QSFP)
NC55-36X100G-BA



Shipping
Now

24 Port 100GE & 12 Port 40GE
External TCAM (QSFP)
NC55-24H12F-SB



Shipping
Now

24 Port 100GE External TCAM (QSFP)
NC55-24X100G-SB



Shipping
Now

36 Port 100GE with MACsec
Internal TCAM (QSFP)
NC55-36X100G-BM



Shipping
Now

18 Port 100GE & 18 Port 40GE
Internal TCAM (QSFP)
NC55-18H18F-BA



Q2
2017

6 Port 100/150/200GE with MACsec
Internal TCAM (CFP2)
NC55-6x200-DWDM-S

NCS 5501 Scale / Base - 1RU Fixed Chassis



← 16 regular ports (ports 0 to 15) →
← 24 ports DWDM/ZR capable (ports 16 to 39) →

NCS-5501-SE

- Power ~ 320W
- Single 800 Gbps FA, 4GB buffer, 600 Mpps
- No Oversubscription
- 40x 10G SFP+ / 4x 100G QSFP28
- Intel Broadwell CPU, with 32GB
8 Cores @ 2GHz
- Front to back / Back to front Airflow Options
- Support of Timing and DWDM interfaces



NCS-5501

- Power ~ 243W
- Single 800 Gbps FA, 4GB buffer, 720 Mpps
- Oversubscribed design, 1.08 Tbps : 800Gbps
- 48x 10G SFP+ / 6x 100G QSFP28
- Intel Broadwell CPU, with 32GB
6 Cores @ 1.9GHz
- Front to back / Back to front Airflow Options
- No DWDM support & timing support

NCS 5502 Scale / Base - 2RU Fixed Chassis



NCS-5502-SE

- 48x 100G QSFP28 (or QSFP+)
- 4.8 Tbps line-rate 100G ~ 1850W
- Scale version with external TCAM
- 8x 600 Gbps Forwarding ASICs
- Front to back / Back to front Airflow Options
- Single Intel Broadwell CPU
12-core @ 1.6GHz

NCS-5502

- 48x 100G QSFP28 (or QSFP+)
- 4.8 Tbps line-rate 100G ~ 1450W
- No external TCAM
- 8x 600 Gbps Forwarding ASICs
- Front to back / Back to front Airflow Options
- Single Intel Broadwell CPU
12-core @ 1.6GHz

- ✓ Cisco NCS 5500 Family Overview
- ✓ **NCS 5500 Features & Scale**
- IOS-XR Innovations
- SPDC Design Options and Examples
- Data Center Interconnect Design
- Conclusion & References

Cisco NCS 5500 Features & Scale

NCS-5500 Software Features

100G-Optimized Scalable IOS XR Router

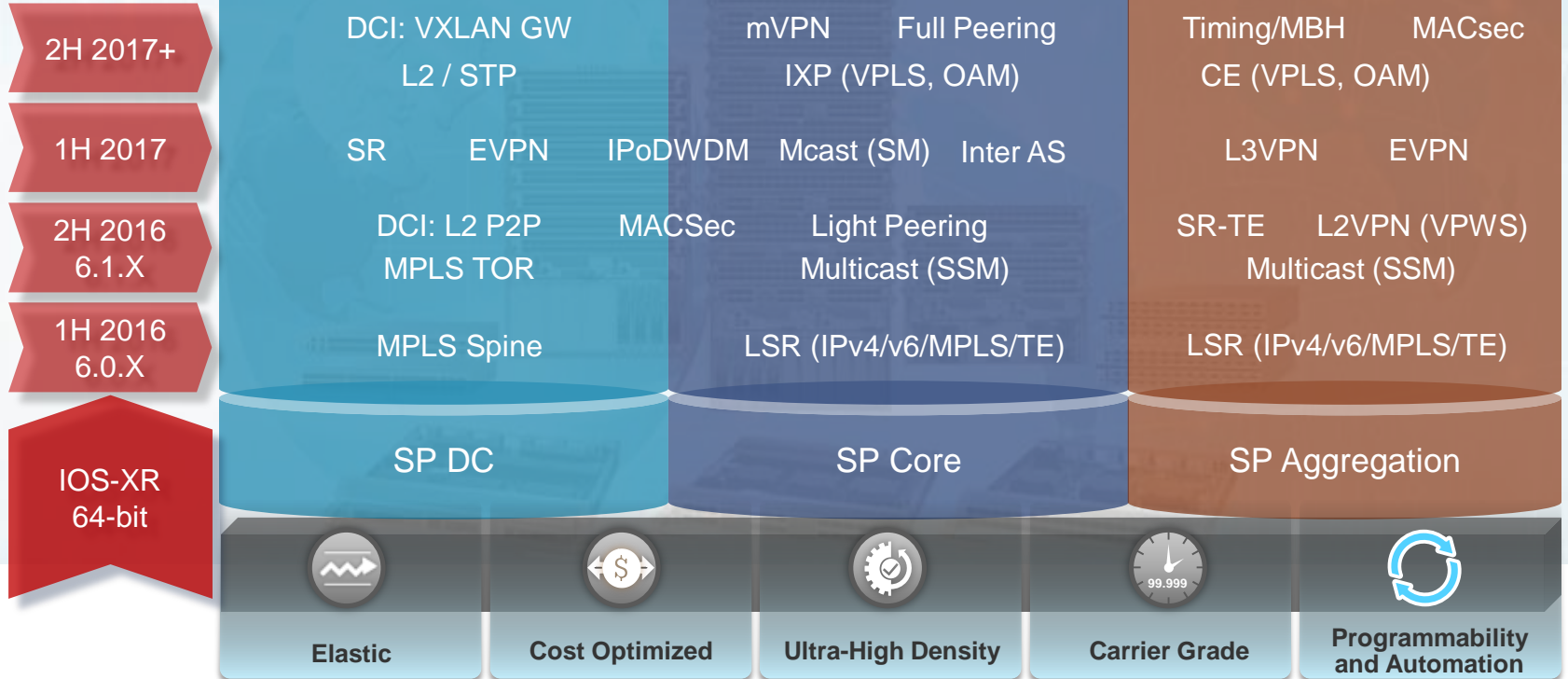

Base Hardware Scalability

- Can handle IPv4/v6 Internet Table with comfortable growth margin

Hardware	LEM	LPM
NCS 5501	750k entries shared between: MPLS labels, MAC addresses, IPv4/32 (default) & Optionally *IPv4 /24, /23 & /20	256k-350k entries shared between IPv4 and IPv6 prefixes, Multicast Groups
NCS 5502		
36 x 100G		
36 x 40G (18H18F)		
36 x 100G MACsec		
6x 200G IPoDWDM		

Scale Hardware Scalability

Hardware	LEM	LPM	eTCAM
NCS 5501-SE	750k entries shared between: MPLS labels, MAC addresses, IPv4/32 & *IPv6/48	64k-160k shared between: IPv6 prefixes (except /48), V4 Multicast Groups	Up to 2M shared between: IPv4 prefixes (non /32)
NCS 5502-SE			
24 x 100G-SE			
24H12F-SE			



IOS-XR Innovations

- ✓ Cisco NCS 5500 Family Overview
- ✓ NCS 5500 Features & Scale
- ✓ **IOS-XR Innovations**
 - SPDC Design Options and Examples
 - Data Center Interconnect Design
 - Conclusion & References

Why XR ??

Cloud Scale networking operations with XR

- Most advanced dominant & well-known OS in the core/WAN space
- Strong MPLS, SR & EVPN feature support
- Scalable & extensible software with open interfaces
- Evolved programmability with model driven operations & common APIs
- Ability to run (host) 3rd party off the shelf apps built with Linux tool chains
- Run apps inside LXC containers with 64-bit Linux host
- Streaming telemetry with software modularity



Cisco Unified Forwarding Plane

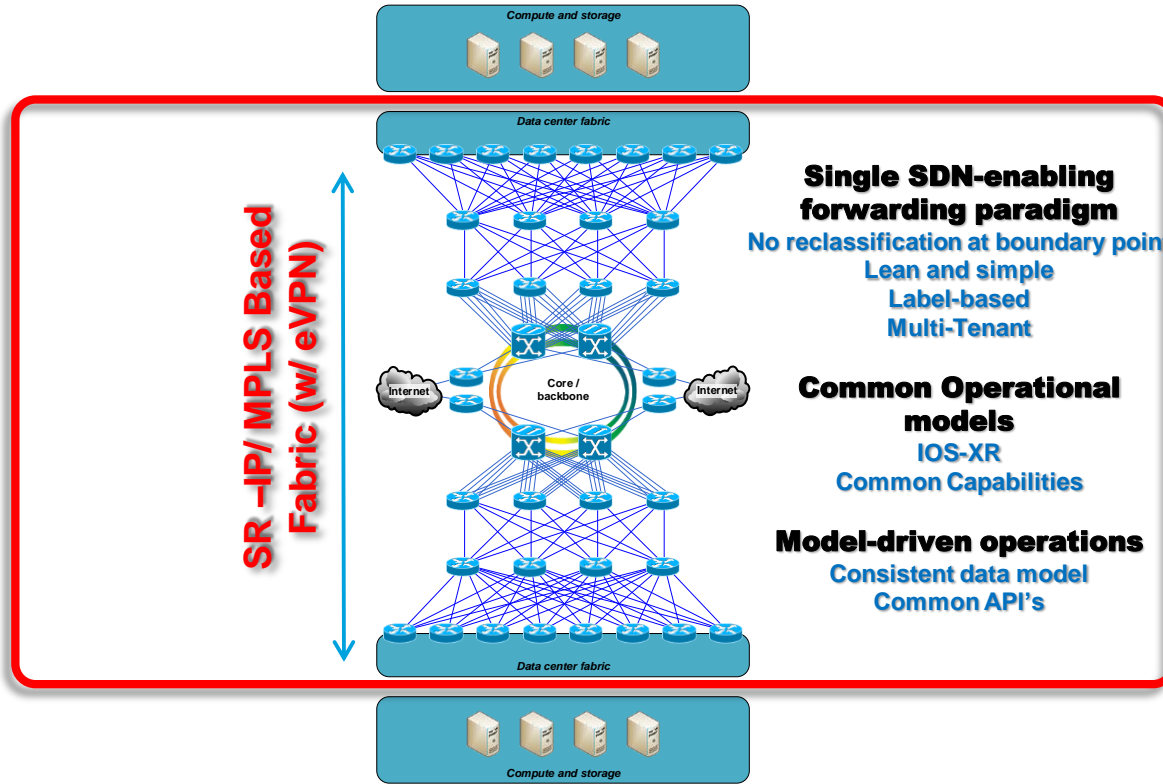
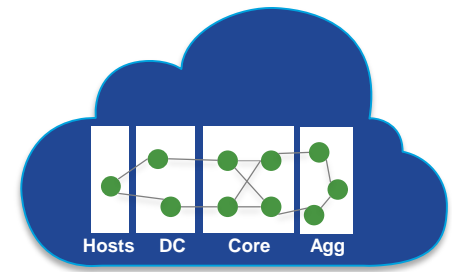

Single SDN-enabling forwarding paradigm
No reclassification at boundary point
Lean and simple
Label-based
Multi-Tenant

Common Operational models
IOS-XR
Common Capabilities

Model-driven operations
Consistent data model
Common API's

Cisco's Unified forwarding Plane

A unified end-to-end fabric based on SR -IP/MPLS & EVPN

Provides common operation models across DC & WAN with IOS-XR

Seamless transport with SR & efficient control plane with EVPN

Unified Forwarding Plane

A fabric solution based on EVPN and Segment Routing

- Segment Routing provides End-to-End seamless transport (IP Fabric (SRv6*) based or MPLS based)
- EVPN control plane minimizes flooding and facilitates learning

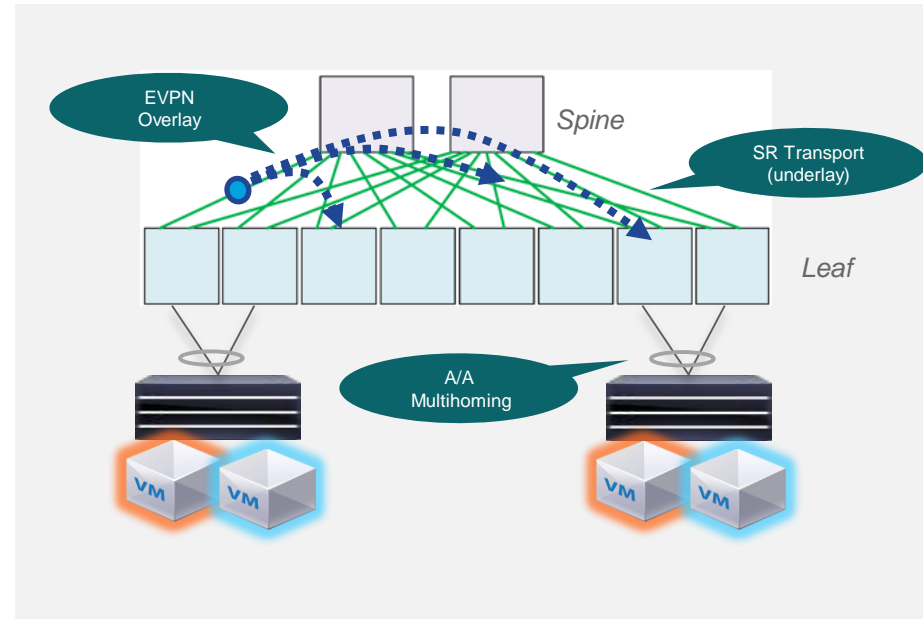

SR

- Explicit Path Control
- Full path programmability
- TE based on application needs

EVPN

- MPBGP for MAC/IP Distribution
- No Pseudowires
- Standardized Multivendor soln

IOS-XR

- Modular & extensible software
- Automation @ scale
- Visibility & Telemetry
- Strong MPLS & SR support

Segment Routing

Segment Routing builds the forwarding plane and provides:

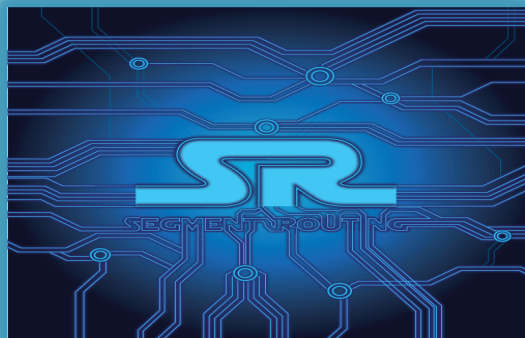

Enables end-to-end policy aware architecture



Tight application-network interaction



Simplified traffic engineering



Efficient data path



Operational simplicity



Full path programmability

EVPN

EVPN builds BGP control-plane for Ethernet Segment and MAC distribution:



Common control plane for L2, L3 & IRB



Per flow redundancy and load balancing



All active multi-homing



Workload mobility



Fast convergence



Standard based multi-vendor solution

EVPN - End-to-End Control-Plane

Common EVPN Control Plane based on BGP: EVPN, PBB-EVPN, EVPN-VPWS

Evolution:

SR (IP/MPLS)

IP, MPLS, VXLAN

IP, MPLS, SR, VXLAN

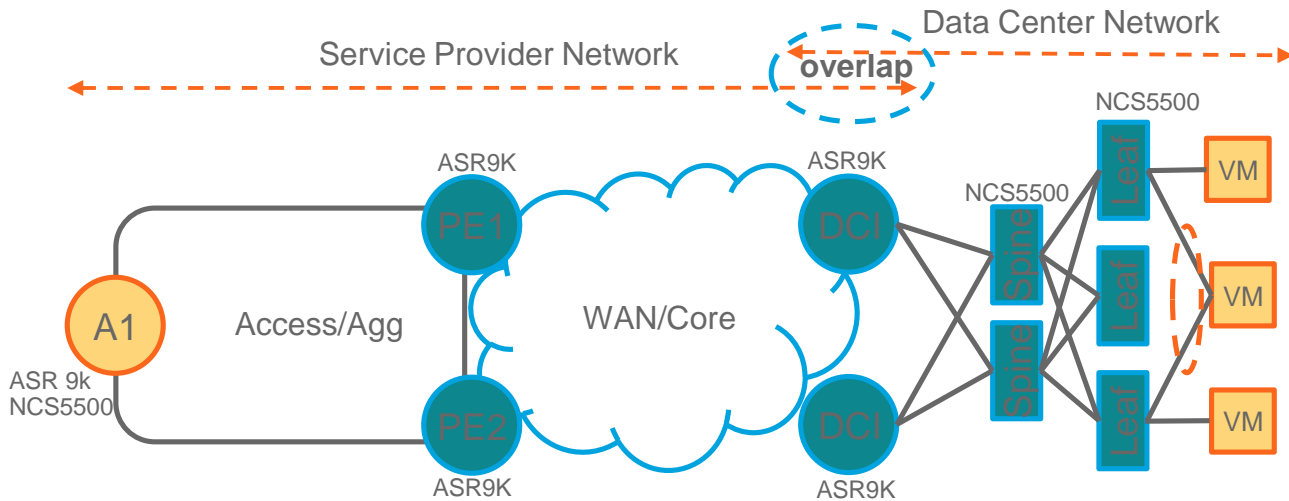

Existing Solution:

L2/L3VPN (BGP,T-LDP) - VPLS, EoMPLS

VPLS

Trill etc

IP, IGP, MPLS (LDP), RSVP-TE, BGP-LU

IP, MPLS, L2

L2, STP, VLAN

- ✓ *Cisco NCS 5500 Family Overview*
- ✓ *NCS 5500 Features & Scale*
- ✓ *IOS-XR Innovations*
- ✓ *SPDC Design Options and Examples*
 - *Data Center Interconnect Design*
 - *Conclusion & References*

SP DC Design Options & Examples

Why Leaf & Spine Clos Fabric?

Most popular & simple design which is easy to change without disrupting the entire network

- Need more host ports? → Add more leaf nodes
- Need more bandwidth? → Add more links and spines

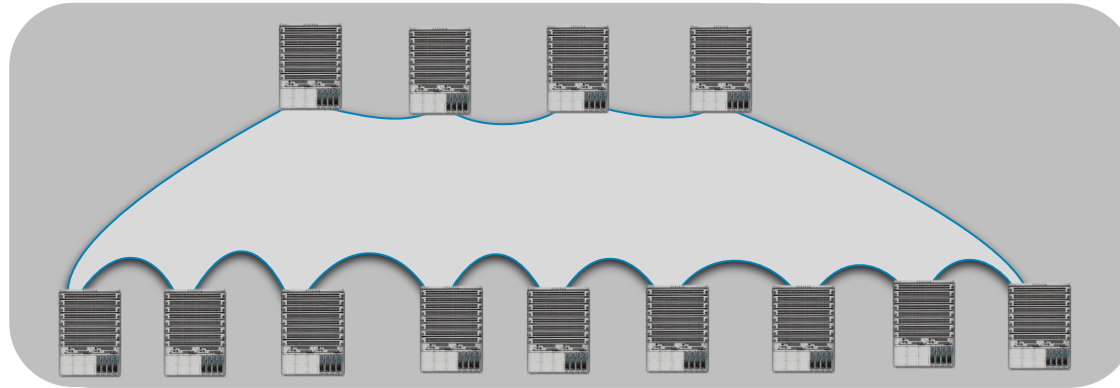

DC Fabric Architecture Evolution

Spine aggregates the leaves and Super Spine aggregates multiple Clos Fabrics

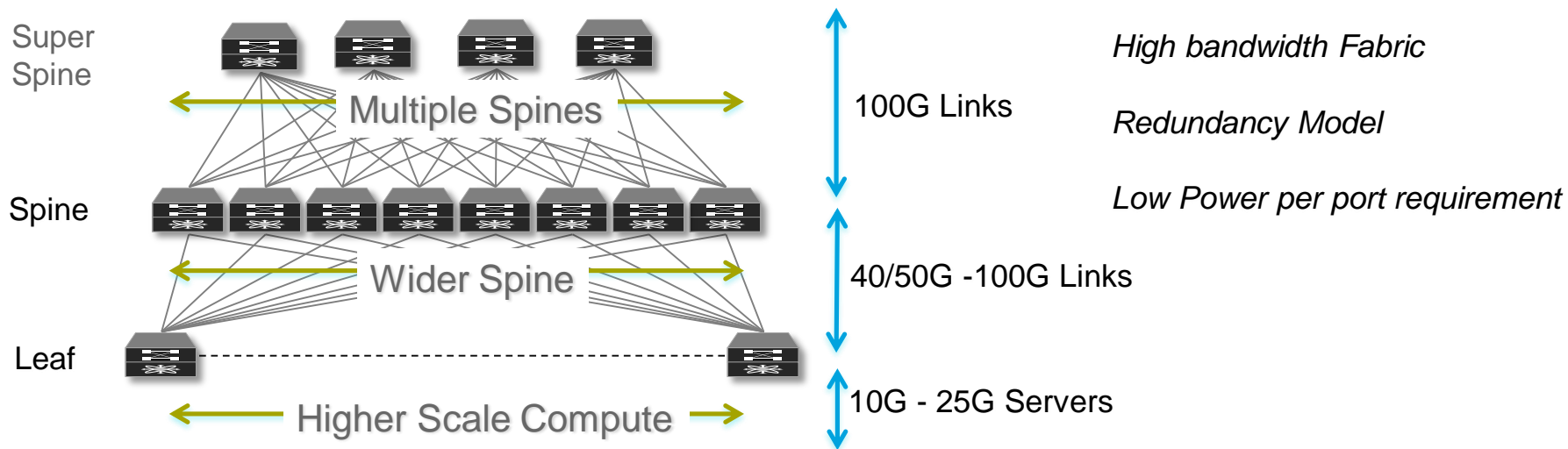

Significant evolution motivated by cloud computing application characteristics

NCS 5000 / 5500 in DC Space

Leaf, Spine & Super Spine Options

Nexus family is primarily positioned for DC space

When to look at NCS 5000 / 5500 as an option for DC ?

- *XR / SR / MPLS enabled DC fabric*
 - Low power / Low per port cost
 - Medium / High Scale & buffer
 - SR / MPLS Transport & eVPN CP
 - High 100G Density in ToR
 - Minimal L2 / VXLAN requirement
 - L2/L3 VPN , Routing scale

→ Low / medium buffer requirement → NCS 5000
→ High buffer requirement → NCS 5500

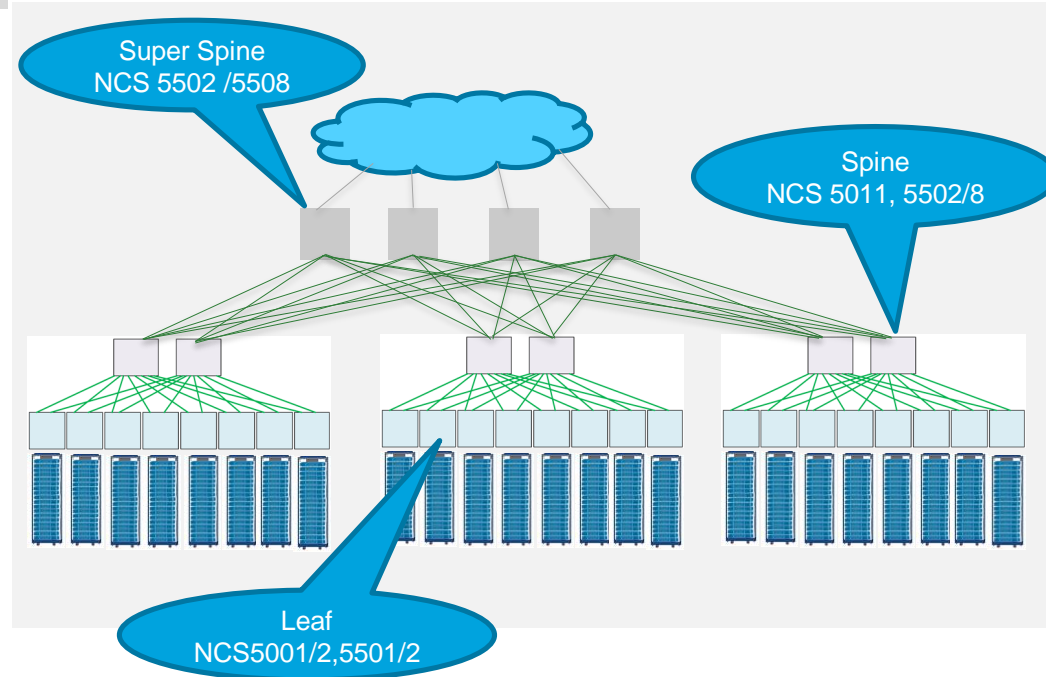

SR/MPLS Enabled DC Architectures for TOR / Spine / Super Spine

Example: 576-1152 10G access Ports

10G Access and 100G Fabric / Core

Highlights:

- Hardware and Software Flexibility
 - NCS5501 – 1G or 10G ports, 40G/100G Uplinks
 - NCS5502 – 40G /100G ports, Pay to grow option
 - Scale or Base options, modular HW/SW
 - Fabric can expand to up to 1728 ports with varying oversubscription ratios
- Architectural Flexibility
 - SR/MPLS/EVPN Based Fabric or
 - Fully L3 based fabric
- Cisco Differentiation
 - Proven, Feature-rich and flexible IOS-XR
 - Very mature SR, MPLS and EVPN Feature sets
 - End to End fabric with Cisco Unified Forwarding

Cisco *live!*

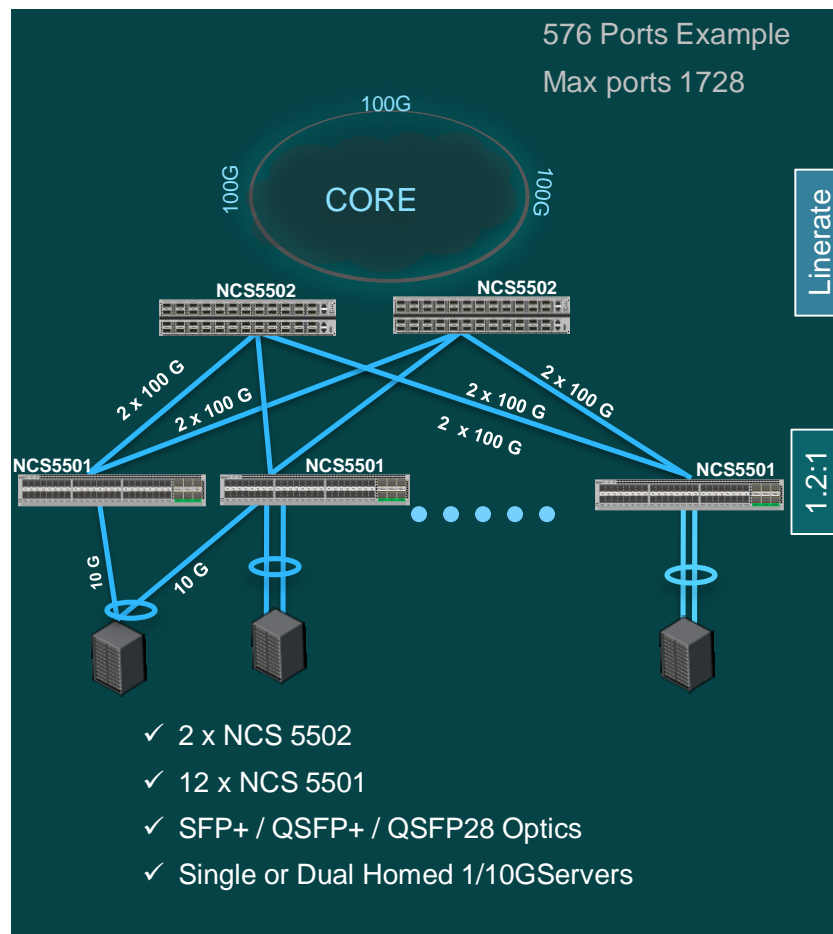

Example: 576-1152 10G access Ports

10G Access and 100G Fabric / Core

Highlights:

- Hardware and Software Flexibility
 - NCS5501 – 1G or 10G ports, 40G/100G Uplinks
 - NCS5502 – 40G /100G ports, Pay to grow option
 - Scale or Base options, modular HW/SW
 - Fabric can expand to up to 1728 ports with varying oversubscription ratios
- Architectural Flexibility
 - SR/MPLS/EVPN Based Fabric or
 - Fully L3 based fabric
- Cisco Differentiation
 - Proven, Feature-rich and flexible IOS-XR
 - Very mature SR, MPLS and EVPN Feature sets
 - End to End fabric with Cisco Unified Forwarding

Cisco *live!*

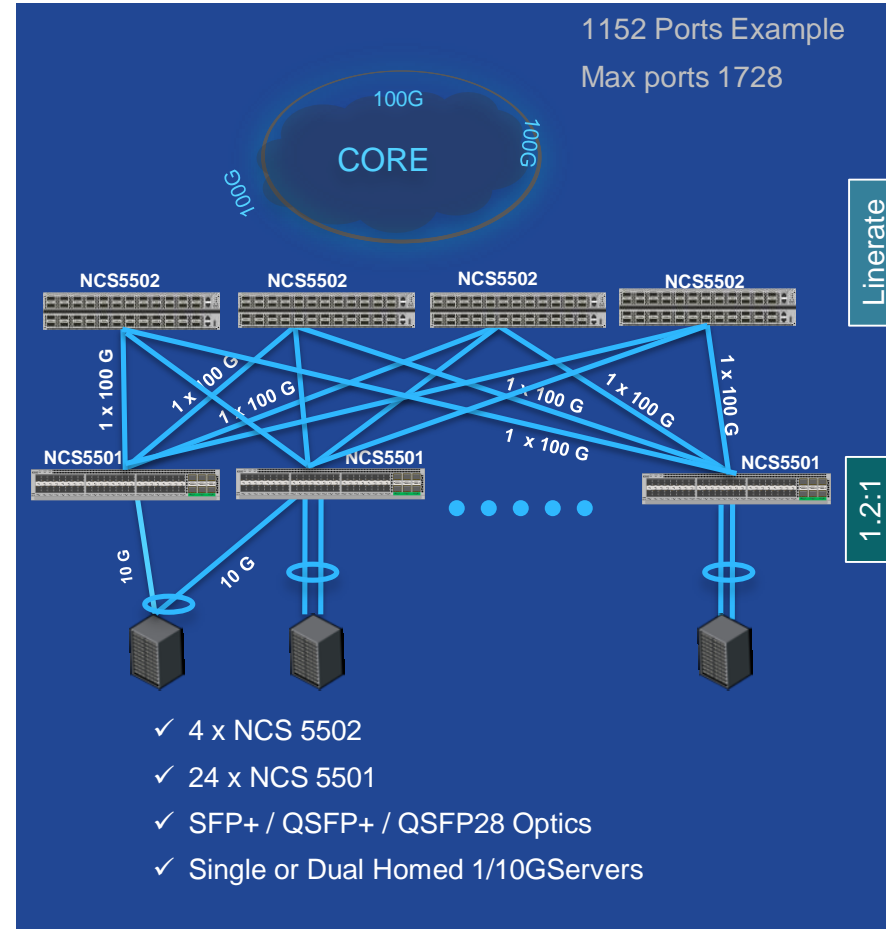

Example: 6000+ 10G Access Ports

100G Fabric and 100G Core

Highlights:

- Build large scalable DC fabrics
 - 12000+ 10G ports with 3:1 Oversubscription
 - 6000+ 10G ports with 1.2:1 Oversubscription
- Fully redundant & highly available fabric
- Architectural Flexibility
 - SR/MPLS/EVPN Based Fabric or
 - Fully L3 based fabric
- Cisco Differentiation
 - Proven, Feature-rich and flexible IOS-XR
 - Very mature SR, MPLS and EVPN Feature sets
 - End to End fabric with Cisco Unified Forwarding

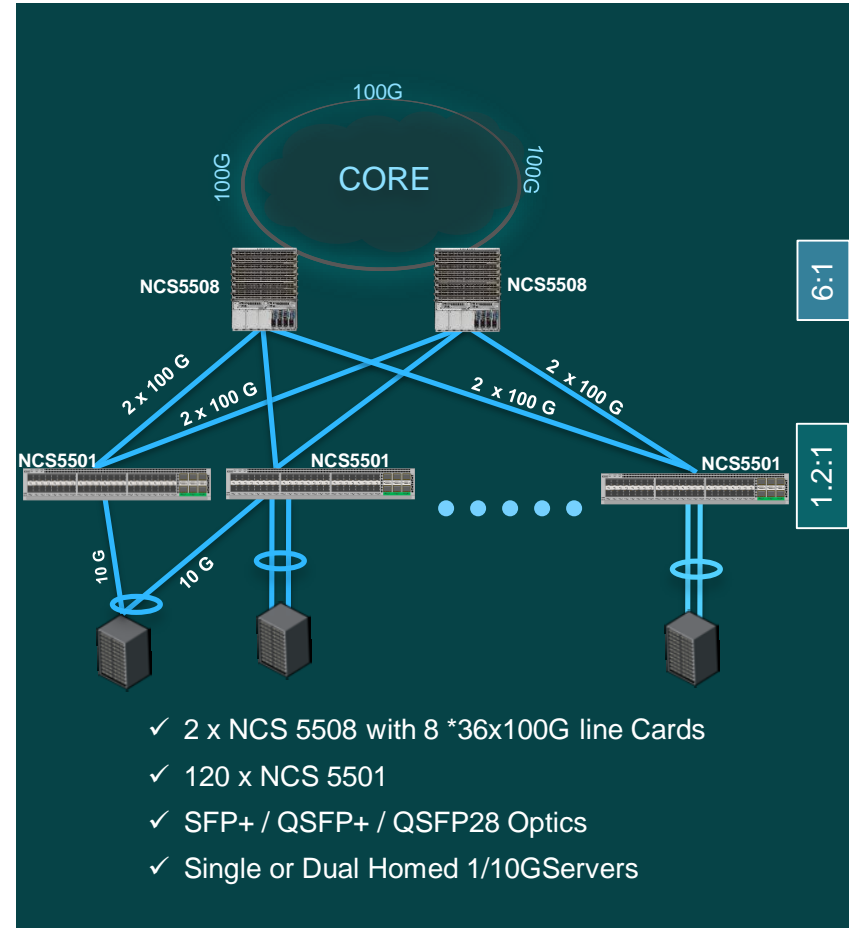

Example: 6000+ 10G Access Ports

100G Fabric and 100G Core

Highlights:

- Build large scalable DC fabrics
 - 12000+ 10G ports with 3:1 Oversubscription
 - 6000+ 10G ports with 1.2:1 Oversubscription
- Fully redundant & highly available fabric
- Architectural Flexibility
 - SR/MPLS/EVPN Based Fabric or
 - Fully L3 based fabric
- Cisco Differentiation
 - Proven, Feature-rich and flexible IOS-XR
 - Very mature SR, MPLS and EVPN Feature sets
 - End to End fabric with Cisco Unified Forwarding

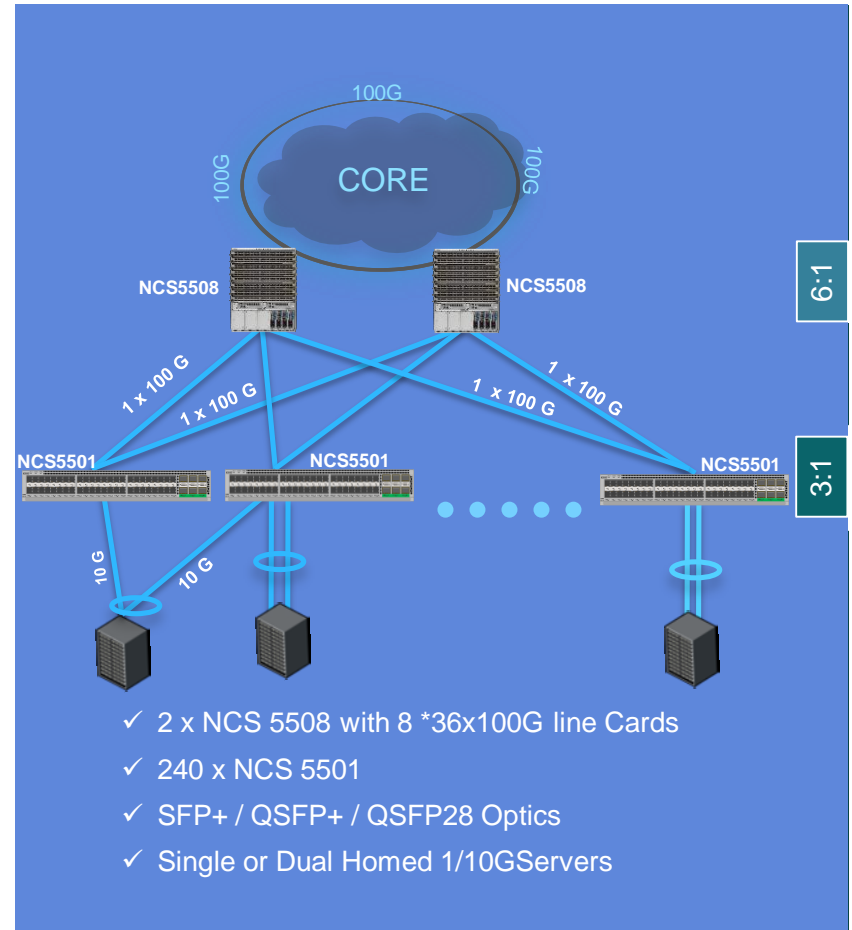

Scaling Out with NCS 5516

100G Fabric and 100G Core

Highlights:

- Build very large scalable DC fabrics
 - 25000+ 10G ports with 3:1 Oversubscription
 - 12500+ 10G ports with 1.2:1 Oversubscription
- Fully redundant & highly available fabric
- Architectural Flexibility
 - SR/MPLS/EVPN Based Fabric or
 - Fully L3 based fabric
- Cisco Differentiation
 - Proven, Feature-rich and flexible IOS-XR
 - Very mature SR, MPLS and EVPN Feature sets
 - End to End fabric with Cisco Unified Forwarding

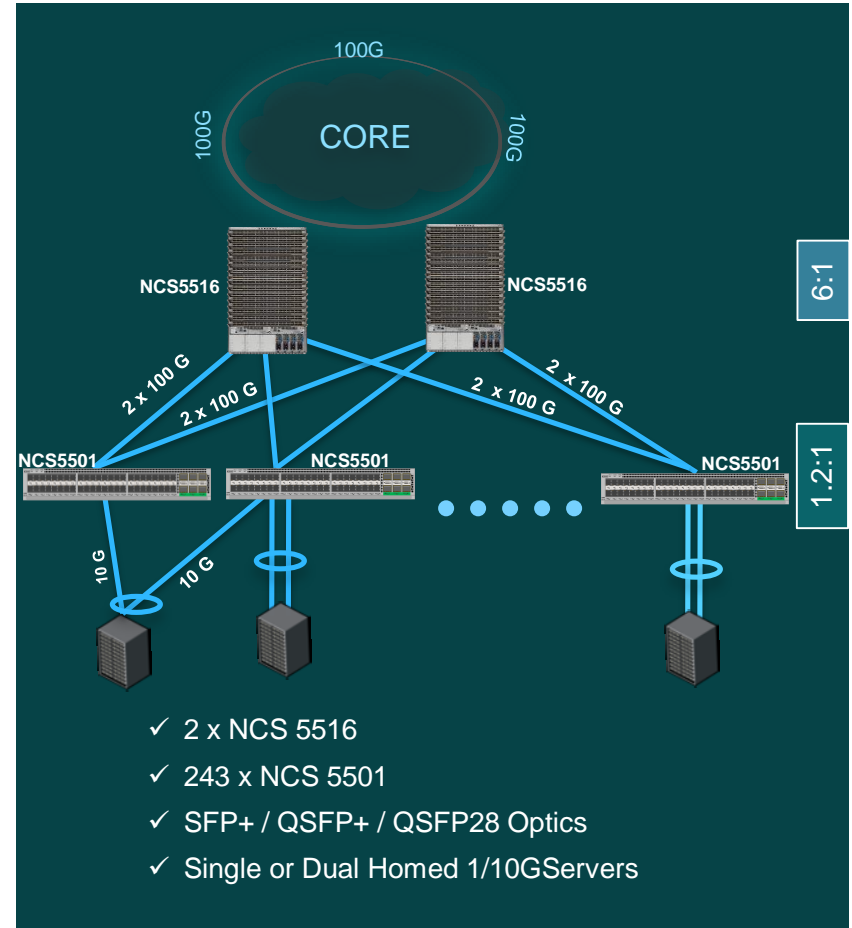

Scaling Out with NCS 5516

100G Fabric and 100G Core

Highlights:

- Build very large scalable DC fabrics
 - 25000+ 10G ports with 3:1 Oversubscription
 - 12500+ 10G ports with 1.2:1 Oversubscription
- Fully redundant & highly available fabric
- Architectural Flexibility
 - SR/MPLS/EVPN Based Fabric or
 - Fully L3 based fabric
- Cisco Differentiation
 - Proven, Feature-rich and flexible IOS-XR
 - Very mature SR, MPLS and EVPN Feature sets
 - End to End fabric with Cisco Unified Forwarding

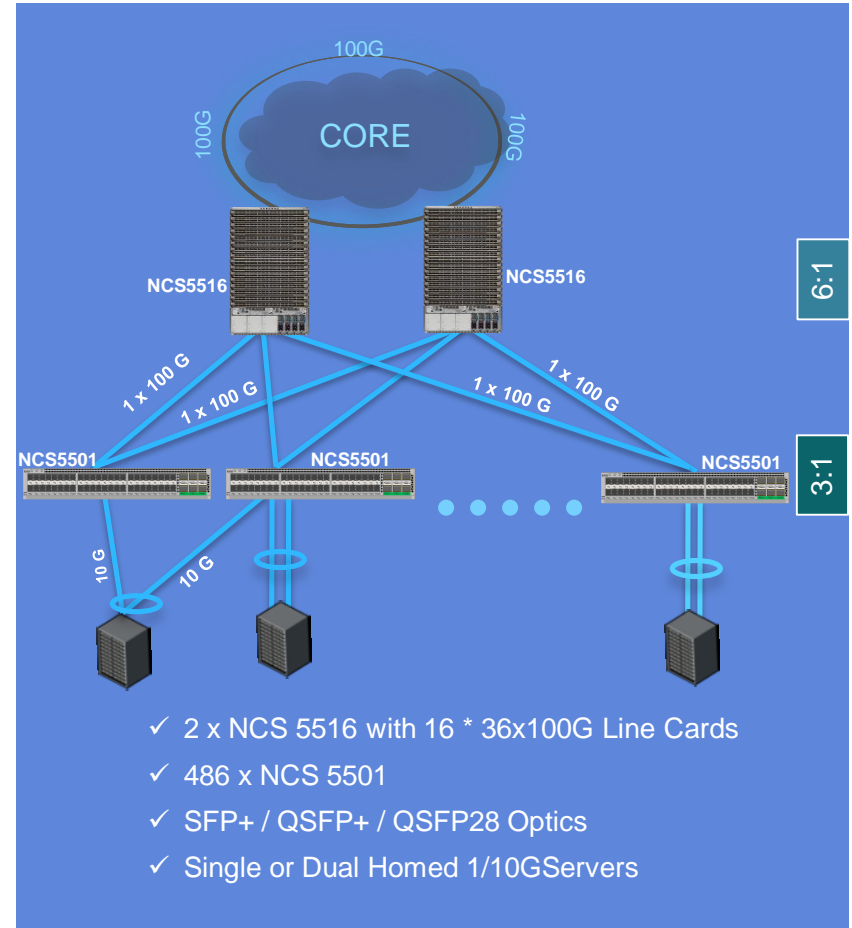

- ✓ *Cisco NCS 5500 Family Overview*
- ✓ *NCS 5500 Features & Scale*
- ✓ *IOS-XR Innovations*
- ✓ *SPDC Design Options and Examples*
- ✓ *Data Center Interconnect Design*
- *Conclusion & References*

Data Center Interconnect Design

Data Center Interconnect – Option 1

Simplify your DC interconnect with NCS5500 Coherent line card



6x 200G Coherent IPoDWDM



Encoding	Reach
100G QPSK	4200 km
150G 8QAM	1800 km
200G 16QAM	1000 km

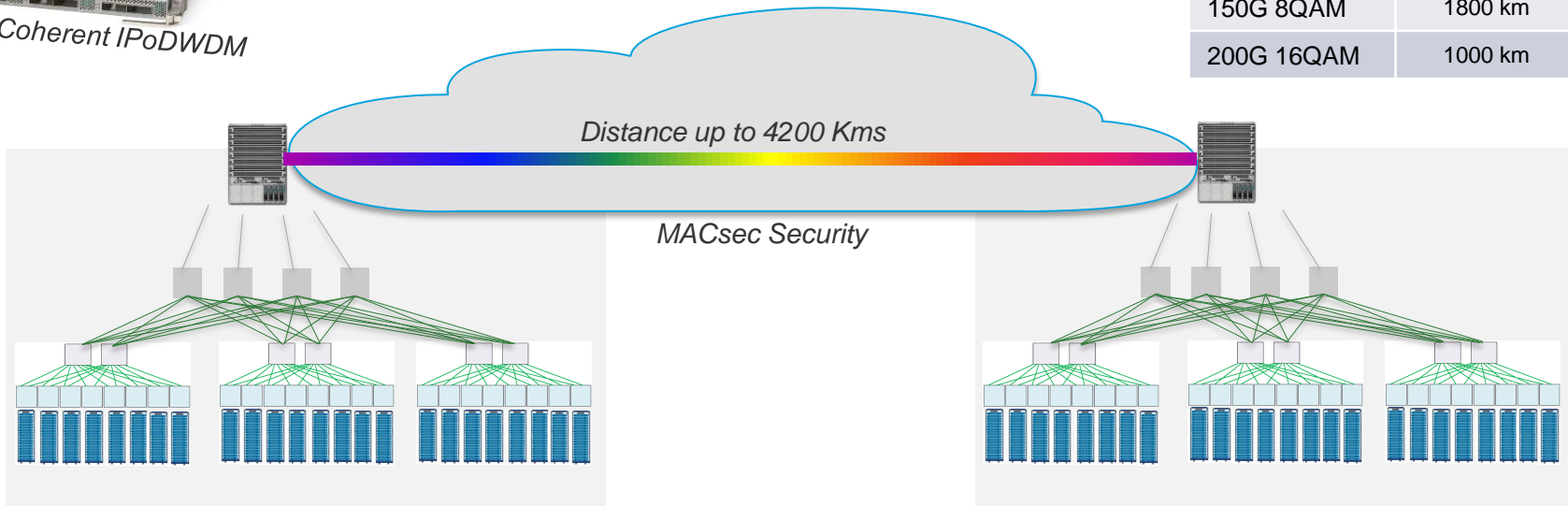

- NCS 5500 6 x 200G Coherent line card provides convenient option for long distance links
- 1.2 Tbps of line rate performance
- Colored optics & Tunable DWDM, pluggable CFP2
- Link security with optional MACsec feature

Data Center Interconnect – Option 2

Longer reach with NCS 5500 and NCS 2000

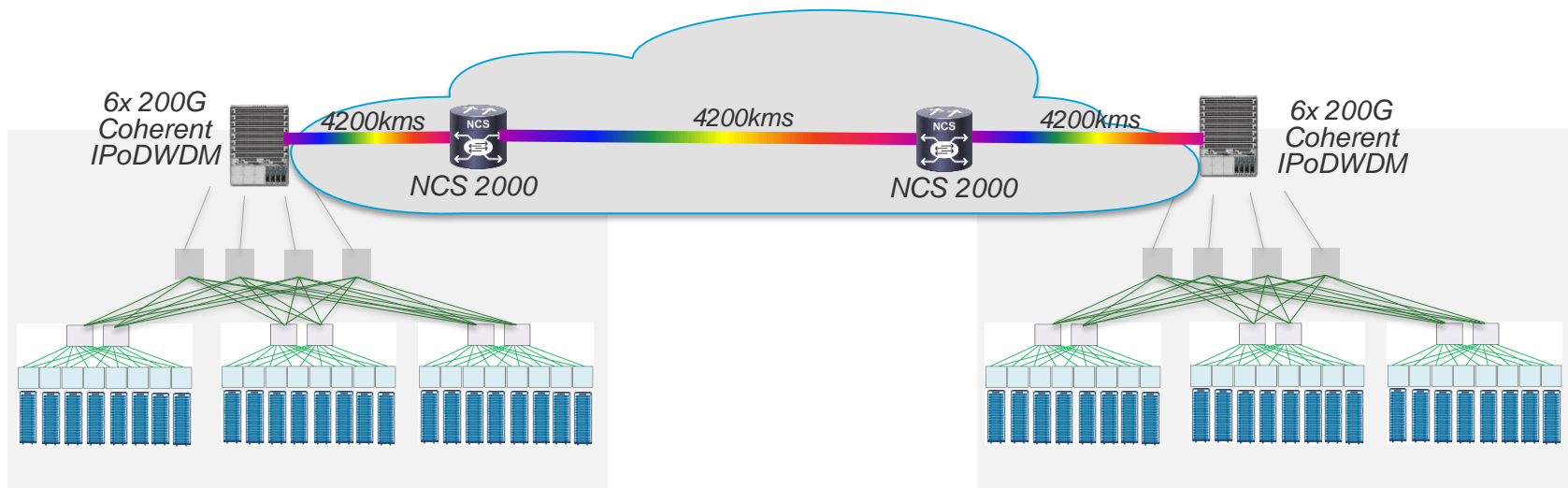

- NCS2Kwith 400G-XP line card provides regen function for longer distances

Data Center Interconnect – Option 3

Interconnect DCs for Cloud Scale - NCS 5500 with Grey Optics to NCS1k

Recommended Sessions

Management (Optical)
BRKNMS-2303

NCS1K
BRKOPT-2000

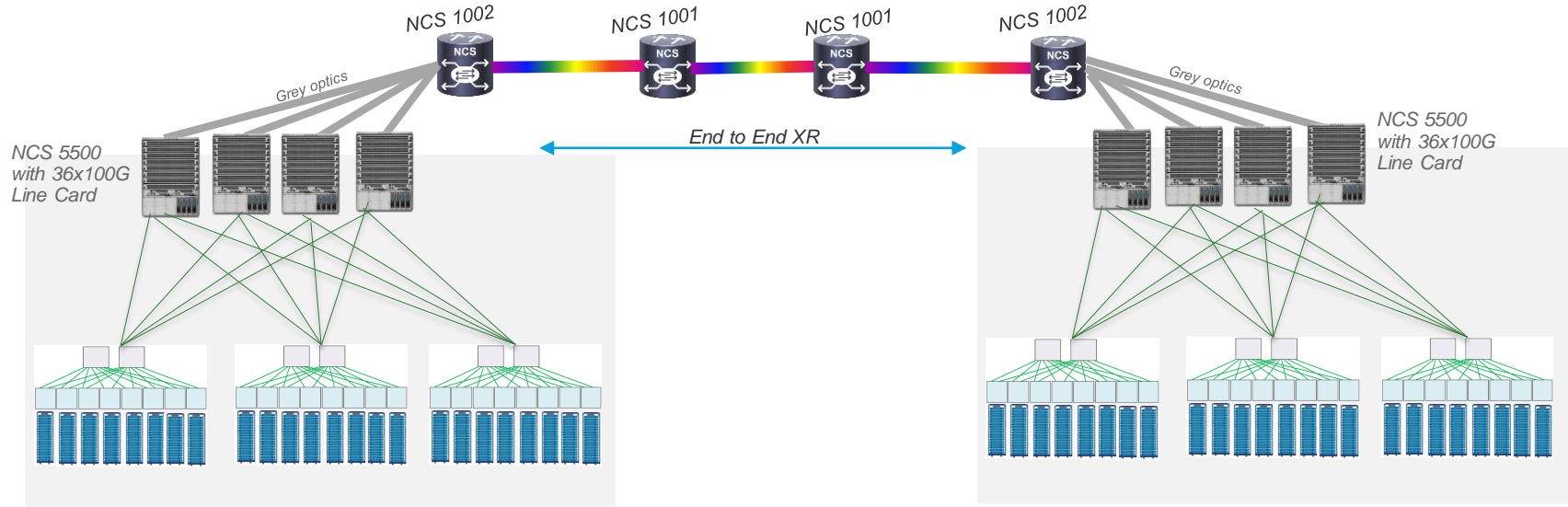

- Simplify the Transport layer with end to end XR
- All the XR benefits such as RPM Packaging, Telemetry, Automation etc
- Recommended Solution for very long distances & High Capacity DCI
- Maximize the DCI Capacity with NCS1002 – 2Tbps in 2RU form Factor

Data Center Interconnect – Option 4

NCS 5500 with Color or Grey Optics handoff to NCS2k

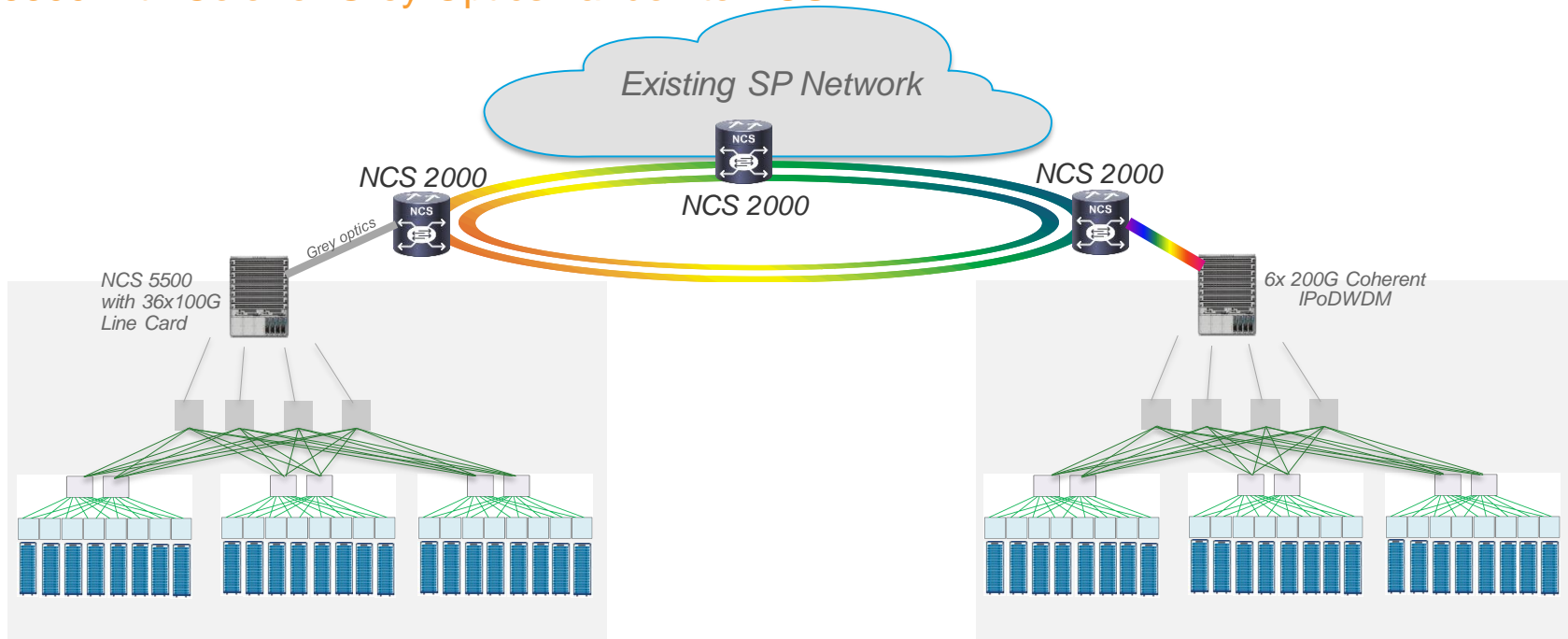

- NCS 5500 Color or Grey optics handoff to NCS2K
- NCS2k provides 1.2 Tbps Capacity with 6RU
→ Suitable when connecting to existing SP networks or multivendor environments

- ✓ Cisco NCS 5500 Family Overview
- ✓ NCS 5500 Features & Scale
- ✓ IOS-XR Innovations
- ✓ SPDC Design Options and Examples
- ✓ Data Center Interconnect Design
- ✓ **Conclusion & References**

Conclusion and References

References

- NCS 5500 Modular Platform Architecture
<http://www.cisco.com/c/dam/en/us/products/collateral/routers/network-convergence-system-5500-series/ncs5500-modular-platform-architecture-white-paper.pdf>
- NCS 5500 Fixed Platform Architecture
<http://www.cisco.com/c/dam/en/us/products/collateral/routers/network-convergence-system-5500-series/ncs5500-fixed-platform-architecture-white-paper.pdf>
- NCS 5000 & NCS 5500 Product Data Sheets
<http://www.cisco.com/c/en/us/products/routers/network-convergence-system-5500-series/datasheet-listing.html> (NCS 5500)
<http://www.cisco.com/c/en/us/products/routers/network-convergence-system-5000-series/datasheet-listing.html> (NCS 5000)
- NCS 5500 Supported Optics
<http://www.cisco.com/c/dam/en/us/products/collateral/routers/network-convergence-system-5500-series/fretta-optics-compatibility-matrix.pdf>
- Cisco Segment Routing
<http://www.cisco.com/c/en/us/solutions/service-provider/cloud-scale-networking-solutions/segment-routing.html>
- Cloud Scale Networking with IOS-XR
<http://www.cisco.com/c/en/us/solutions/service-provider/cloud-scale-networking-solutions/index.html>

Conclusion

Industry Leadership with Cloud Scale Networking

**INDUSTRY
LEADERSHIP**

**CONTINUED
INNOVATION**

**INVESTMENT
PROTECTION**

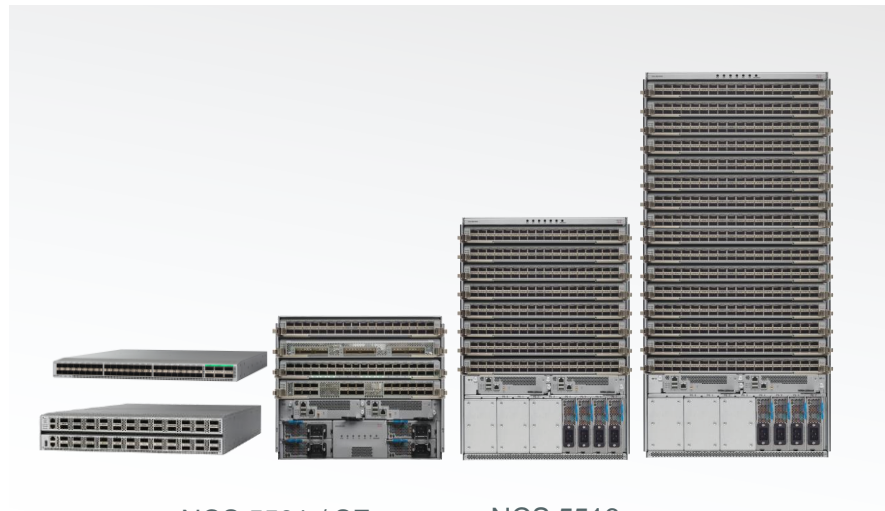

NCS 5001 / 5002
NCS 5508
36 X 100G LC

NCS 5011

24x100G SE LC
18H18F LC

NCS 5501 / SE
NCS 5502 / SE
24H12F SE LC

NCS 5516
36 x 100G
MACSEC LC

6 x 200G
IPoDWDM LC

NCS 5504
Additional Features
and
Density
10/25/40/50/100G

2H
2015

1H
2016

2H
2016

2H
2016

Early
2017

1H
2017

Future

Complete Your Online Session Evaluation

- Please complete your Online Session Evaluations after each session
- Complete 4 Session Evaluations & the Overall Conference Evaluation (available from Thursday) to receive your Cisco Live T-shirt
- All surveys can be completed via the Cisco Live Mobile App or the Communication Stations



Don't forget: Cisco Live sessions will be available for viewing on-demand after the event at CiscoLive.com/Online

Continue Your Education

- Demos in the Cisco campus
- Walk-in Self-Paced Labs
- Lunch & Learn
- Meet the Engineer 1:1 meetings

Q & A

Thank You

Cisco *live!*
February 20 - 24, 2017 • Berlin



Your Time Is Now